

150W Ku-Band
 1:2 Phase Combined
 SSPA System

DESCRIPTION

Teledyne Paradise Datacom's family of outdoor packaged, phase combined SSPA systems provide the highest degree of redundancy and system reliability.

1:1 Phase Combined Systems are an economical solution to providing high output power capability with soft-fail redundancy. 1:2 Phase Combined Systems can provide full output power redundancy to mission critical applications which cannot tolerate any decrease in output power capability.

Both 1:1 and 1:2 Phase Combined Systems utilize a signal box through which all RF and L-band input signals are distributed. This ensures that any reference signal is modulated to each amplifier at the same frequency, and that the phase adjustment is optimized.

FEATURES

- Extremely High Power Density:
 - 1.6 kW L-Band;
 - 1.6 kW S-Band;
 - 1.6 kW C-Band;
 - 1.6 kW X-Band;
 - 1.2 kW Ku-Band
- Universal Power Factor Corrected Power Supply
- System Output Power Monitor
- Hot/Cold Standby operating modes for reduced power consumption

OPTIONS

- Hand Held Controller
- Reflected Power Monitor
- Waveguide Arc Protection Kit
- L-Band Input Operation
- SSPA and Controller Remote Panels
- Auxiliary / Maintenance Output Switch
- Cold Standby Operation for Prime Power Savings
- Custom Configurations

1:1 Phase Combined / Redundant System

The 1:1 Fixed Phase Combined System is a popular system architecture that enables two amplifiers to operate as a normal 1:1 redundant system or as a phase combined system. The basic system topology is similar to a 1:1 redundant system and is shown in the block diagram. An additional switch is included which allows either amplifier to be individually connected to the antenna or connect both amplifiers to a waveguide combiner.

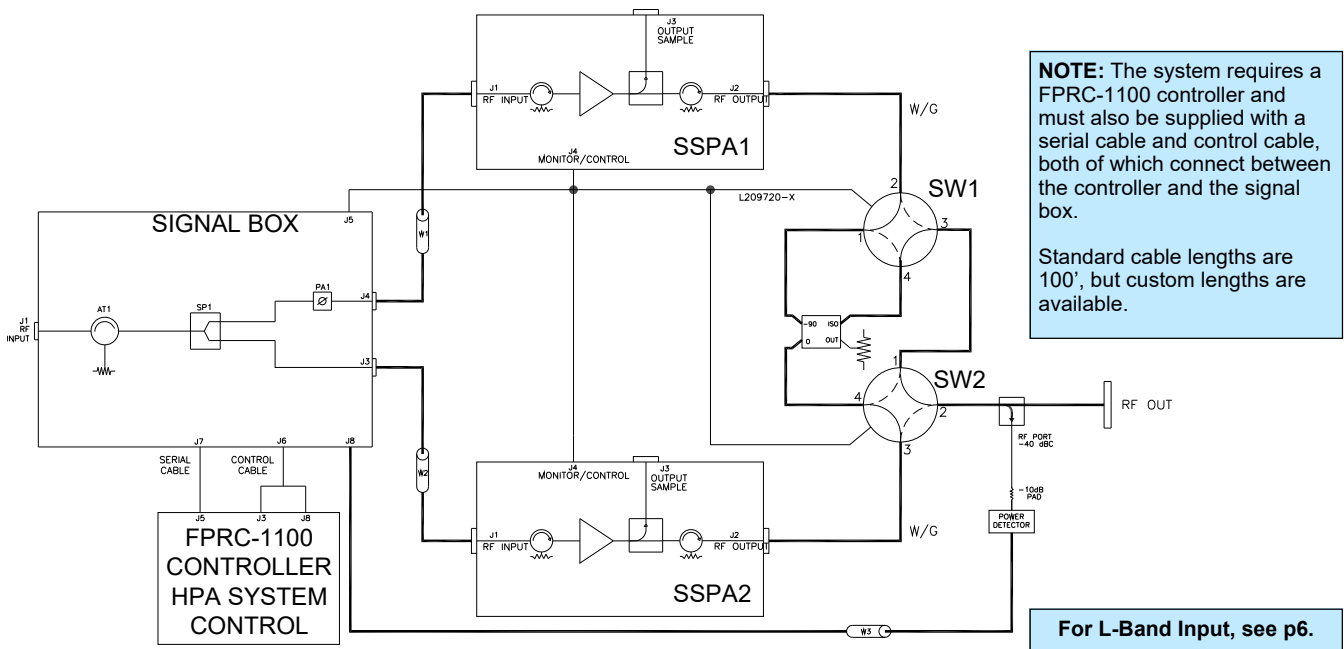

Phase Combined System Controller — FPRC-1100

The 1RU FPRC-1200 Controller is the heart of the 1:1 Phase Combined System. It provides an extremely user friendly interface for complete monitor and control of the high power amplifiers. The front panel mimic display shows the on-line amplifiers and the switch positions. Fault lights are provided for easy indication of system status.

All FPRC-1100 monitor and control is available locally at the front panel LCD display, as well as remotely by the RS232, RS485, or Ethernet interface ports. Audible alarms and a full compliment of parallel I/O signal are available at the rear panel of the FPRC-1100.

The FPRC-1100 System Controller allows the Phase Combined System of amplifiers to be controlled as if it were a single SSPA. The controller is the single point of interface for either local, front panel, or remote control. System monitor and control capability include gain adjustment, output power monitoring (dBm or Watts), and alarms.

1:2 Phase Combined / Redundant System

The 1:2 Phase Combined System is a system architecture that enables amplifiers to achieve higher output power levels while building in a level of redundancy. Basic system topology is similar to a 1:2 redundant system, but with a single output POL, shown in the block diagram below. SSPA1 and SSPA3 are normally online. The outputs of SSPA1 and SSPA3 are directed by the waveguide switches into a low loss power combiner. In the event of a failure of an online amplifier, the standby amplifier (SSPA2) is switched in place of the failed amplifier and the system maintains **full output power**.

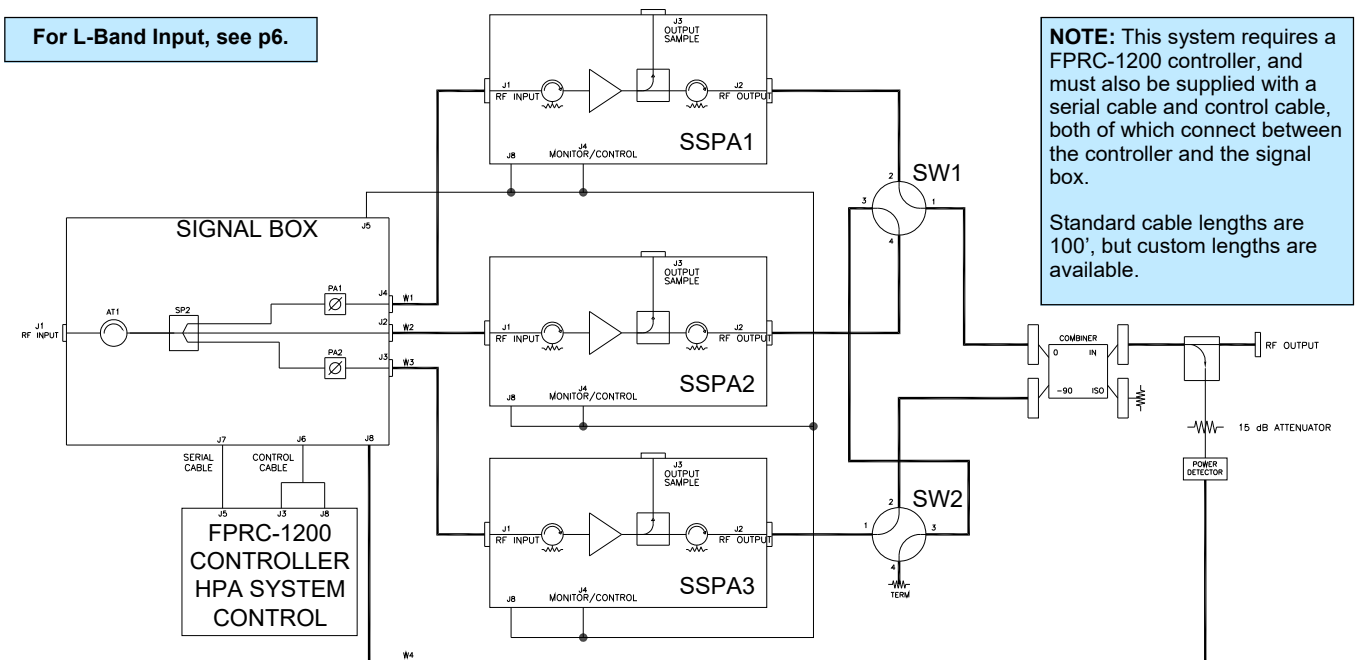

Phase Combined System Controller — FPRC-1200

The 1RU FPRC-1200 Controller is the heart of the 1:2 Phase Combined System. It provides an extremely user friendly interface for complete monitor and control of the high power amplifiers. The front panel mimic display shows the on-line amplifiers and the switch positions. Fault lights are provided for easy indication of system status.

All FPRC-1200 monitor and control is available locally at the front panel LCD display, as well as remotely by the RS232, RS485, or Ethernet interface ports. Audible alarms and a full complement of parallel I/O signal are available at the rear panel of the FPRC-1200.

The FPRC-1200 System Controller allows the Phase Combined System of amplifiers to be controlled as if it were a single SSPA. The controller is the single point of interface for either local, front panel, or remote control. System monitor and control capability include gain adjustment, output power monitoring (dBm or Watts), and alarms.

Outdoor Systems are configured with Teledyne Paradise Datacom's new High Power Outdoor SSPA or popular Compact Outdoor SSPA packages

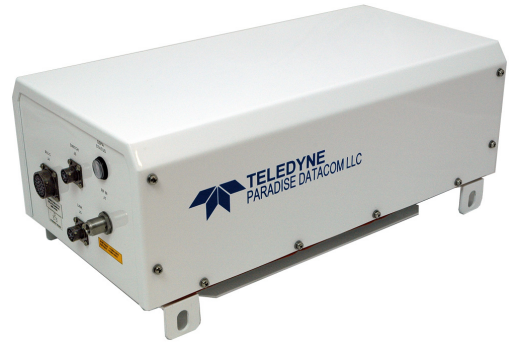

High Power Outdoor Output Power Ranges

Band	GaAs (W)	GaN (W)
L-Band	N/A	600 - 800
S-Band	N/A	600 - 800
C-Band	400 - 500	800
X-Band	N/A	800
Ku-Band	N/A	400 - 600

See document # 214164 for GaAs High Power Outdoor SSPAs, and document # 211669 for GaN High Power Outdoor SSPAs

Compact Outdoor Output Power Ranges

Band	GaAs (W)	GaN (W)
L-Band	N/A	100 - 500
S-Band	N/A	100 - 500
C-Band	100 - 300	300 - 400
X-Band	200	300 - 400
Ku-Band	N/A	200 - 250

See document # 205485 for GaAs Compact Outdoor SSPAs, and document # 209555 for GaN Compact Outdoor SSPAs

System Output Power Capacity

Due to the output waveguide and switches, there is always some residual loss in the output of phase combined HPA systems. This results in slightly less than the ideal 3 dB power addition to the output power of a single HPA unit.

On 1:1 phase combined systems, the typical additive output power is 2.70 dB above the output power of a single HPA. On 1:2 phase combined systems, the typical additive output power is 2.50 dB above the output power of a single HPA.

For example, a 200W C-Band Compact Outdoor SSPA in a 1:1 phase combined system would have the following output power:

Single Compact Outdoor HPA: $P_{1dB} = 52.3 \text{ dBm}$; $P_{sat} = 53.0 \text{ dBm}$
 1:1 phase combined system: $P_{1dB} = 55.0 \text{ dBm}$; $P_{sat} = 55.7 \text{ dBm}$

Continuous operation at saturated power can negatively impact the life of the amplifier and will not be covered by warranty. Normal operating output should be limited to P_{linear} (3dB backed off from the full rated power, P_{sat}) for GaN amplifiers, or limited to P_{1dB} for GaAs amplifiers.

General System Specifications

PARAMETER	NOTES	LIMITS	UNITS
Gain	minimum	70	dB
Gain Flatness	minimum (units with L-Band input)	67	dB
	full band	± 1.0	dB
	full band (Extended C-Band)	± 1.5	dB
Gain Slope	per 40 MHz	± 0.3	dB/40 MHz
	per 10 MHz (L-, S-Band)	± 0.2	dB/10 MHz
Gain Variation vs. Temperature	-30 °C to +50 °C	± 1.0	dB
Gain Stability	at constant temperature	± 0.25	dB/24 hours
Gain Adjustment	0.1 dB resolution	20	dB
Intermodulation Distortion	@ P _{1dB} - 3 dB	-25	dBc
AM/PM Conversion	@ rated P _{1dB}	3.5	°/dB
	@ P _{1dB} - 3 dB	1.0	°/dB
Spurious Harmonics	@ rated P _{1dB}	-65	dBc
	@ rated P _{1dB} - 3 dB (C-, X-, Ku-Bands)	-50	dBc
	@ rated P _{1dB} - 3 dB (L-, S-Band)	-30	dBc
Input/Output VSWR		1.50:1	
	Output VSWR: Ku-Band with bulkhead filter	1.40:1	
Group Delay (per 40 MHz segment)	Linear	0.01	ns/MHz
	Parabolic	0.003	ns/MHz ²
	Ripple	1.0	ns p-p
Transmit Band Noise Output Power Density	TX Band	-75	dBW/4 KHz
	RX Band (C-, Ku-Bands)	-150	dBW/4 KHz
	RX Band (X-Band)	-100	dBW/4 KHz
	RX Band (L-, S-Band)	See options	
Receive Band Noise Output Power Density	L-/S-Band, with optional filter	-155	dBW/4 KHz
	L-/S-Band, without optional filter	-95	dBW/4 KHz
Residual AM Noise	0 - 10 KHz	-45	dBc
	10 KHz - 500 KHz	-20 (1.25 + log F)	dBc
	500 KHz - 1 MHz	-80	dBc
Phase Noise	Offset frequency from carrier		
	10 Hz	-90	dBc/Hz
	100 Hz	-100	dBc/Hz
	1 KHz	-110	dBc/Hz
	10 KHz	-120	dBc/Hz
	100 KHz	-125	dBc/Hz
	1 MHz	-130	dBc/Hz

Environmental

Operating Temperature	Ambient	-40 to +60	°C
Relative Humidity	Condensing	100	%
Cooling System	Integrated	Forced air	

Mechanical

Size, High Power Outdoor	width X length X height	21.0 X 27.95 X 13.5	inches
		533 X 710 X 343	mm
Size, Compact Outdoor	width X length X height	10.0 X 19.5 X 6.50	inches
		254 X 495 X 165	mm
Weight, High Power Outdoor		100 (45.5)	lbs.(kg)
Weight, Compact Outdoor	Base unit (< 200W S/C-bands; < 100W Ku)	36 (16.4) ± 3%	lbs.(kg)
	Base unit (≥ 200W S/C-bands; ≥ 100W Ku)	44 (20.0) ± 3%	lbs.(kg)
	Base unit (< 200W X-Band)	46.7 (21.1) ± 3%	lbs.(kg)
	Base unit (≥ 200W X-Band)	54.9 (25.0) ± 3%	lbs.(kg)
	With Internal zBUC	+1.7 (0.8)	lbs.(kg)
Finish		Paint	White; powder coat

L-Band Operation

Teledyne Paradise Datacom Phase Combined Systems can be configured for L-Band Input Operation. For optimum RF phase combining over the entire bandwidth of a communication amplifier, the frequency translation part of the system must be separated from the phase combining loop. Therefore, systems with L-Band input are configured with a separate 1:1 system of L-Band Block Up Converters that feed the 1:1 or 1:2 Phase Combined HPA system.

NOTE: The RCP2-1100 BUC System Controller must be supplied with a control cable, which connects between the controller and the signal box. Standard cable length is 100', but custom lengths are available.

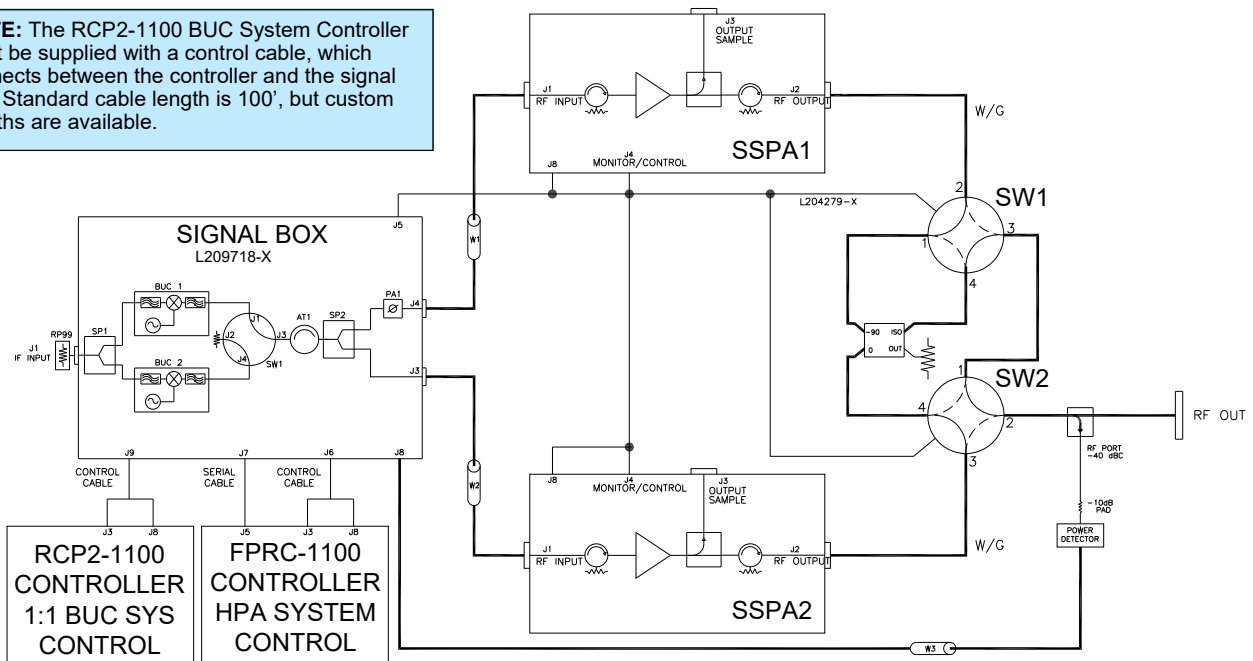

The Block Up Converter system is housed in a weather-proof enclosure (shown below) and is controlled by an indoor RCP2-1100 Redundant Controller. The Teledyne Paradise Datacom ZBUC[®] converter architecture allows a converter that is fitted with an internal reference oscillator to automatically detect and switch to an externally applied 10 MHz reference signal.



L-Band Operation

Teledyne Paradise Datacom amplifiers are available with an integrated L-Band Block Up Converter. L-Band units utilize Teledyne Paradise Datacom's proprietary zBUC technology. Adding a zBUC[®] converter to an SSPA typically increases the gain by 2-4 dB. In addition:

- Autosensing zBUC includes an internal reference but will switch to an external reference if applied;
- Internal high stability (10 MHz) reference; will lock to externally supplied (10 or 50 MHz) reference;
- zBUC converter can accept a wide range of external reference power (-10 to +5 dBm);
- zBUC converter can accept FSK monitor and control signal via the IFL for complete amplifier remote control.

Available Frequency Plans

Band	Model Number	IF Input	LO Frequency	RF Output
C	Sub-Band "A"	950 - 1525 MHz	4.900 GHz	5.850 - 6.425 GHz
C	Sub-Band "B"	950 - 1825 MHz	4.900 GHz	5.850 - 6.725 GHz
C	Sub-Band "C"	950 - 1870 MHz	4.800 GHz	5.750 - 6.670 GHz
X	Sub-Band "A"	950 - 1450 MHz	6.950 GHz	7.900 - 8.400 GHz
Ku	Sub-Band "A"	950 - 1450 MHz	13.050 GHz	14.00 - 14.50 GHz
Ku	Sub-Band "B"	950 - 1700 MHz	12.800 GHz	13.75 - 14.50 GHz

EAR99 Technology Subject to Restrictions Contained on the Back Page.

Electrical Specifications for Outdoor SSPA with ZBUC converter

PARAMETER	NOTES	LIMITS				UNITS
Gain	Nominal setting	75				dB
Gain Flatness	full band (C-,X-,Ku-bands)	± 2.0				dB
Gain Slope	per 40 MHz (C-,X-,Ku-bands)	± 0.5				dB/40 MHz
Gain Adjusted Range		20				dB
	Typical C-Band Adj. Range	60 - 80				dB
	Typical Ku-Band Adj. Range	57 - 77				dB
Gain Stability	-40 to +60 °C	± 1.5				dB
Phase Noise	Offset frequency from carrier	<u>Absolute max.</u>	<u>C-band (typ.)</u>	<u>X-band (typ.)</u>	<u>Ku-band (typ.)</u>	
	10 Hz	-30	-60	-58	-56	dBc/Hz
	100 Hz	-60	-74	-70	-67	dBc/Hz
	1 KHz	-70	-84	-80	-78	dBc/Hz
	10 KHz	-80	-100	-94	-91	dBc/Hz
	100 KHz	-90	-105	-97	-94	dBc/Hz
	1 MHz	-90	-125	-122	-120	dBc/Hz
Spurious	In-Band Signal Related (C-/Ku-Band) (Extended C-Band)	-50				dBc
	Close to Carrier Spurious (≤ 20 MHz)	-40				dBc
	Local Oscillator	-30				dBm
Transmit Band Noise Output Power Density	Tx Band at Maximum gain	-65				dBW/4kHz
Input VSWR	L-Band	1.5 : 1				
Internal Reference Option	Reference Accuracy (initial)	± 1 • 10 ⁻⁸				
	Aging per day (after 30 days)	± 1 • 10 ⁻⁹				
	Aging per year (after 30 days)	± 6 • 10 ⁻⁸				
	Reference Stability over Temperature (-40 to +40 °C, ambient)	± 1 • 10 ⁻⁸				

Part Number Configuration, GaAs High Power Outdoor SSPA System

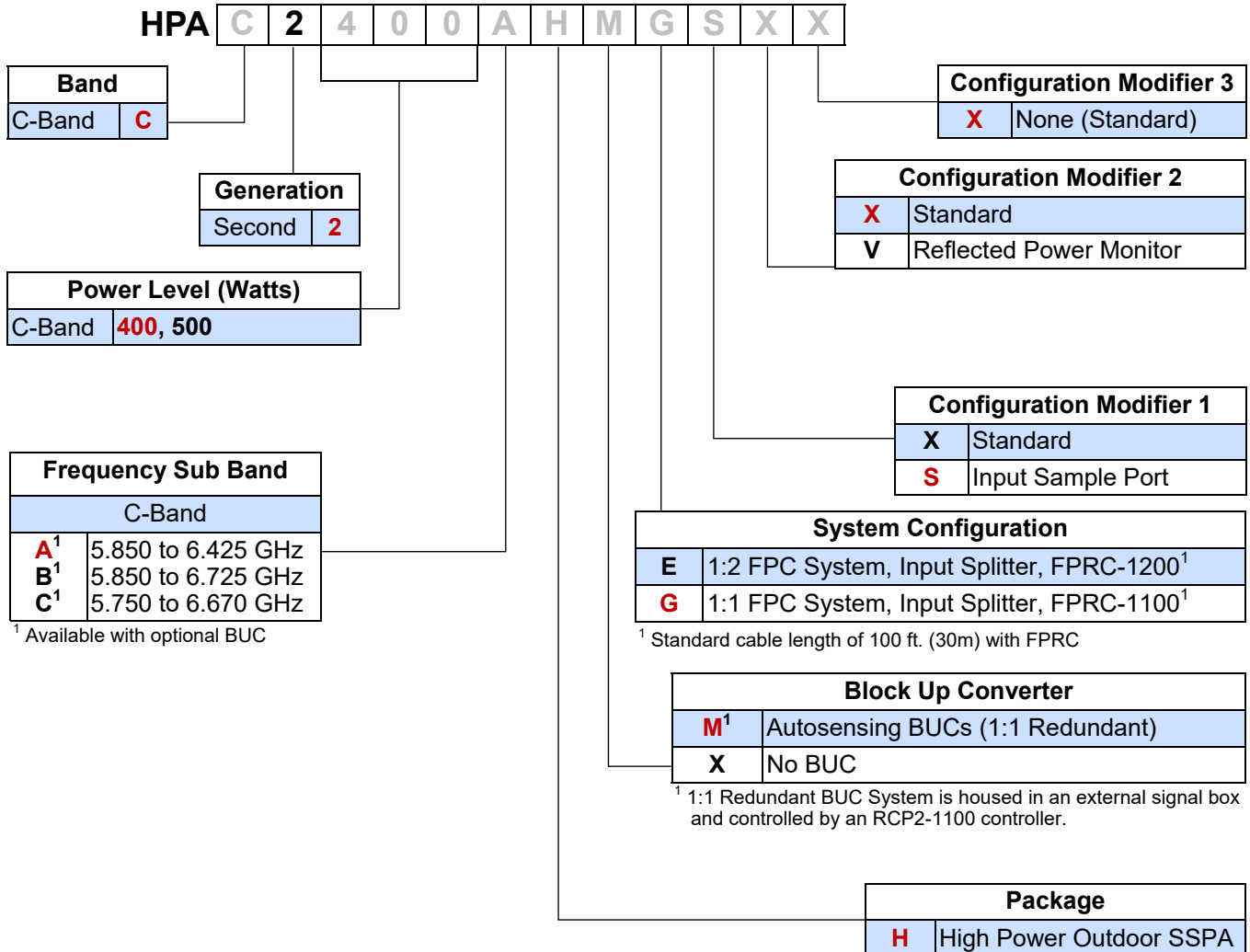

EAR99 Technology Subject to Restrictions Contained on the Back Page.

Example - A 1:1 Fixed Phase Combined 400W system utilizing two (2) GaAs C-Band High Power Outdoor SSPA with optional input sample ports and optional internal reference block up converters is part number: **HPAC2400AHMGSXX**.

For standalone SSPA specifications, refer to document 214164.

COMMENTS:

Part Number Configuration, GaN High Power Outdoor SSPA System

HPA C 2 8 0 0 A H M G S X X G

Band	
L-Band	L
S-Band	S
C-Band	C
X-Band	X
Ku-Band	K

Generation	
Second	2

Power Level (Watts)	
L-Band	600, 800
S-Band	600, 800
C-Band	800
X-Band	800
Ku-Band	400, 500, 600

Frequency Sub Band	
L-Band	
A	1.75 to 1.85 GHz
S-Band	
A	2.02 to 2.12 GHz
B	2.20 to 2.30 GHz
G	1.75 to 2.12 GHz
C-Band	
A ¹	5.850 to 6.425 GHz
B ¹	5.850 to 6.725 GHz
C ¹	5.750 to 6.670 GHz
X-Band	
A ¹	7.90 to 8.40 GHz
F	7.10 to 7.40 GHz
Ku-Band	
A ¹	14.00 to 14.50 GHz
B ¹	13.75 to 14.50 GHz

¹ Available with optional BUC

GaN Device Designator	
G	GaN Technology

Configuration Modifier 3	
X	None (Standard)

Configuration Modifier 2	
X	Standard
R ¹	Receive Band Reject Filter
V	Reflected Power Monitor
Y ¹	R + V (see above)

¹ S-Band and X-Band only

Configuration Modifier 1	
X	Standard
S	Input Sample Port

System Configuration	
E	1:2 FPC System, Input Splitter, FPRC-1200 ¹
G	1:1 FPC System, Input Splitter, FPRC-1100 ¹

¹ Standard cable length of 100 ft. (30m) with FPRC

Block Up Converter	
M ¹	Autosensing BUCs (1:1 Redundant)
X	No BUC

¹ 1:1 Redundant BUC System is housed in an external signal box and controlled by an RCP2-1100 controller.

Package	
H	High Power Outdoor SSPA

EAR99 Technology Subject to Restrictions Contained on the Back Page.

For standalone SSPA specifications, refer to document 211669.

Example - A 1:1 Fixed Phase Combined 800W System utilizing two (2) GaN C-Band High Power Outdoor SSPAs with optional input sample ports and optional internal reference block up converters is part number: **HPAC2800AHMGSXXG**.

COMMENTS:

Part Number Configuration, GaAs Compact Outdoor Systems

HPA **C 2 2 0 0 A C X G X X X**

Band	
C-Band	C
X-Band	X

Generation	
Second	2

Power Level (Watts)	
C-Band	100, 140, 200, 250, 300
X-Band	200

Frequency Sub Band	
C-Band	
A ¹	5.850 to 6.425 GHz
B ¹	5.850 to 6.725 GHz
C ¹	5.750 to 6.670 GHz
X-Band	
A ¹	7.90 to 8.40 GHz

¹ Available with optional BUC

Package	
C	Compact Outdoor SSPA

Configuration Modifier 3	
X	None (Standard)
A	Side-mount AC Input, Location 'A'
D	48 VDC Input
F	Side-mount 48 VDC Input, Location 'A'

Configuration Modifier 2	
X	Standard
M	MS-Connector Covers
R ¹	Receive Band Reject Filter
S ¹	M + R (see above)

¹ X-Band only

Configuration Modifier 1	
X	Standard
K	110 VAC Input

¹ Available in C- and X-Band models ≥ 140W

System Configuration	
E	1:2 FPC System, Input Splitter, FPRC-1200 ¹
G	1:1 FPC System, Input Splitter, FPRC-1100 ¹

¹ Standard cable length of 100 ft. (30m) with FPRC unit.

Block Up Converter	
M ¹	Autosensing BUCs (1:1 Redundant)
X	No BUC

¹ 1:1 Redundant BUC System is housed in an external signal box and controlled by an RCP2-1100 controller.

For standalone SSPA specifications, refer to document 205485.

Example - A 1:1 phase combined standard frequency 200W C-Band Compact Outdoor SSPA system with input splitter and no BUC, and using a FPRC-1100 system controller, is part number: **HPAC2200ACXGXXX**.

COMMENTS:

Part Number Configuration, GaN Compact Outdoor Systems

HPA **X** **2** **3** **0** **0** **A** **C** **M** **J** **X** **X** **X** **G** **GaN Device Designator**
G GaN Technology

Band	
L-Band	L
S-Band	S
C-Band	C
X-Band	X
Ku-Band	K

Generation	
Second	2

Power Level (Watts)	
L-Band	100, 200, 300, 400, 500
S-Band	100, 200, 300, 400, 500
C-Band	300, 400
X-Band	300, 400
Ku-Band	200, 250

Frequency Sub Band	
L-Band	
A	1.75 to 1.85 GHz
S-Band	
A	2.02 to 2.12 GHz
B	2.20 to 2.30 GHz
G	1.75 to 2.12 GHz
C-Band	
A ¹	5.850 to 6.425 GHz
B ¹	5.850 to 6.725 GHz
C ¹	5.750 to 6.670 GHz
X-Band	
A ¹	7.90 to 8.40 GHz
Ku-Band	
A ¹	14.00 to 14.50 GHz
B ¹	13.75 to 14.50 GHz

¹ Available with optional BUC

Configuration Modifier 3	
X	None (Standard)
A	Side-mount AC Input, Location 'A'

Configuration Modifier 2	
X	Standard
M	MS-Connector Covers
R ¹	Receive Band Reject Filter
S ¹	M + R (see above)

¹ S-Band and X-Band only

Configuration Modifier 1	
X	Standard
K ¹	110 VAC Input Power

¹ Available on all C-Band units, all X-Band units, Ku-Band units > 150W

System Configuration	
E	1:2 FPC System, Input Splitter, FPRC-1200 ¹
G	1:1 FPC System, Input Splitter, FPRC-1100 ¹

¹ Standard cable length of 100 ft. (30m) with FPRC unit.

Block Up Converter	
M ¹	Autosensing BUCs (1:1 Redundant)
X	No BUC

¹ 1:1 Redundant BUC System is housed in an external signal box and controlled by an RCP2-1100 controller.

Package	
C	Compact Outdoor SSPA

For standalone SSPA specifications, refer to document 209555.

Example - A 1:1 phase combined standard frequency 300W X-Band GaN Compact Outdoor SSPA system with input splitter and internal control with an external reference BUC is part number: **HPAX2300ACMJXXXG**.

COMMENTS:

Global Sales Offices

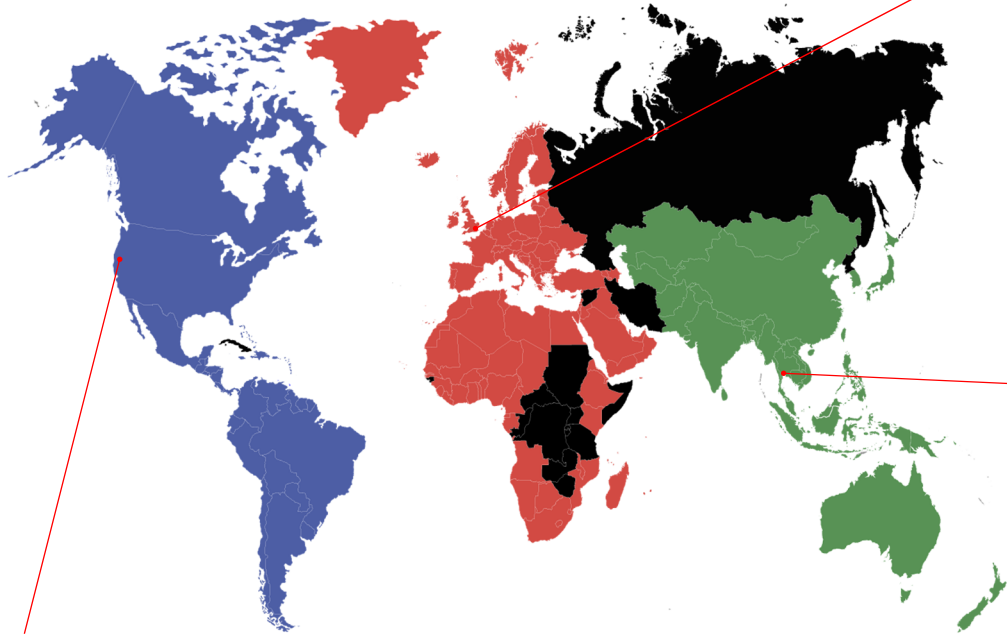

U.S. HEADQUARTERS (RF)
Teledyne Paradise Datacom
11361 Sunrise Park Drive
Rancho Cordova, CA 95742
sales@paradisedata.com

Global Business Development & Sales Director (RF)
Timothy Sheerin, (508) 273-5902
timothy.sheerin@teledyne.com

Sales Director, Eastern U.S. & Latin America (RF)
John O'Grady, (848) 220-6464
john.ogrady@teledyne.com

Sales Director, Western U.S. & Canada (RF & Modem)
Bruce Grieser, (480) 444-9676
bruce.grieser@teledyne.com

U.K. HEADQUARTERS (Modem)
**Global Business Development
& Sales Director (Modem)**
Paul McConnell
Teledyne Paradise Datacom
106 Waterhouse Lane,
Chelmsford,
Essex, England, CM1 2QU
Tel: +44(0)1245 847520
Mobile: +44(0)7720 707499
paul.mcconnell@teledyne.com

**Sales Director,
Asia Pacific (RF & Modem)**
Tavechai M.
Teledyne Paradise Datacom
333, 20 Fl., C1
Lao Peng Nguan Tower 1,
Vibhavadi-Rangsit Rd.,
Chatuchak, Bangkok 10900
Thailand
Tel: +66 2-272-2996
Mobile: +66 83 5545145
tavechai.mektavepong@teledyne.com

Use and Disclosure of Data: This product is classified as EAR99 and is subject to U.S. Department of Commerce regulations. Export, reexport or diversion contrary to U.S. law is prohibited.

Proprietary and Confidential: The information contained in this document is the sole property of Teledyne Paradise Datacom. Any reproduction in part or as a whole without the written permission of Teledyne Paradise Datacom is prohibited.

Data Security: Teledyne Paradise Datacom amplifiers and controllers do not inherently provide encryption to transmitted data, and have limited security measures to protect it. If the unit will be accessible over the Internet, exercise appropriate data security protocols. Teledyne Paradise Datacom strongly recommends placing the equipment behind a protective Firewall or setting up a VPN link with dual authentication for remote access.

Specifications are subject to change without notice.