

### The New Standard in High Power Redundant Microwave Amplifier Systems Has Arrived



4kW C Band Solid State High Power Amplifier System  
configured with (8) Modules

#### FEATURES

- Output Power levels of up to:  
5.9 kW in C-Band  
2.4 kW in X-Band
- No Active Switching-All Passive Power Combining
- System is 100% field maintainable
- Output Power sized for n+1 Redundancy
- All active modules are hot swappable via the front or rear panels
- System can be configured with any combinations of 4 to 16 modules.
- Hot Swappable Redundant Power Supply Modules
- Hot Swappable SSPA Modules
- Color Touchscreen Displays
- Removable Fan Trays
- Removable M&C Card Assembly
- System monitor and control emulates single SSPA Chassis operation
- Ethernet Port with UDP, SNMP, and internal web browser capability
- Legacy RS485 M&C
- Accurate Output Power Measurement
- Reflected Power Monitor
- RF Output Sample Port (-50 dB)
- RF Gain Adjustment (50 dB - 70 dB)
- System is field scalable: i.e., can start out with (4) modules in system and upgrade to (8) or (16) modules.
- Hot/Cold Standby operating modes for reduced power consumption
- Optional Waveguide Arc Protection Kit

**System Configurations and Soft-Fail Output Power**



**(8) Module System with 600W C Band Chassis**  
**Single cabinet system [31RU]**

Number of Modules in System	System Output Power, Psat dBm (Watts)	Reduction in Output Power (dB)
8	66.0 dBm (3981 W)	0
7	64.8 dBm (3020 W)	-1.2
6	63.6 dBm (2291 W)	-2.4
5	62.0 dBm (1585 W)	-4.0
4	60.0 dBm (1000 W)	-6.0
3	57.5 dBm (562 W)	-8.5

**(8) Module, 4kW C-Band System comprised of (8) 600W C Band modules**



**(16) Module System with 300W C Band Chassis**  
**Dual cabinet system [62RU]**

Number of Modules in System	System Output Power, Psat dBm (Watts)	Reduction in Output Power (dB)
16	65.4 dBm (3467 W)	0
15	64.8 dBm (3020 W)	-0.6
14	64.2 dBm (2630 W)	-1.2
13	63.4 dBm (2188 W)	-2.0
12	62.9 dBm (1950 W)	-2.5
11	62.4 dBm (1738 W)	-3.0

**(16) Module, 4kW C-Band System comprised of (16) 300W C-Band modules**



### System Operation

The PowerMAX system maintains complete parallel redundancy down to the embedded control level. Therefore the loss of an entire HPA chassis will not interrupt remote communications with the system. Remote communications can be either RS-485 or Ethernet. The system will automatically correct its gain level in the event of one or more HPA chassis failures.

The sophisticated system monitor and control allows the system to be locally or remotely operated as if it were a “single” chassis amplifier. The system control maintains a hierarchical management that allows the operator to interface to a single chassis of the multi-module array.

Another feature unique to Paradise Datacom’s PowerMAX is the introduction of “true rms” output power measurement. Unlike other amplifier systems that utilize diode detection schemes, the PowerMAX reports the true rms output power of the system independent of the number of carriers and modulation schemes.

Proprietary waveguide combining techniques are employed so that maximum power combining efficiency is optimized within the operating frequency band.

### System Output Power and Configurations

Because the system power combining is purely passive and no switching is used, there is never an interruption in RF output power. The PowerMAX system is typically used as a “self-redundant” system. The output power is sized such that the loss of (1) RF module’s power will still allow the system to maintain its minimum required output power. This type of system architecture is described as n+1 redundant. The system can be configured with any number of modules but best overall efficiency is obtained with the popular binary combinations of 4, 8, or 16 modules. It is very easy to upgrade the PowerMAX system from 4 modules to 8 or 16 modules in the field. It is not necessary to fully populate the system at the time of initial purchase. This provides the user a path to upgrade output power capability as system requirements grow, thus keeping capital investment minimized. For sizing redundant output power capability use the following guideline to determine the output power of the system with the loss of (1) module.

4 Module System - 3 of 4 Modules Operable = 2.5 dB loss in output power capability

8 Module System - 7 of 8 Modules Operable = 1.2 dB loss in output power capability

16 Module System - 15 of 16 Modules Operable = 0.6 dB loss in output power capability



### System Prime Input Power

Proprietary adaptive bias techniques are utilized to achieve an aggressive balance between RF output power and minimized DC input power.

Prime power may be introduced into a terminal block at the top of the cabinet. Electrical conduit is routed between the terminal block and a 5RU boxed assembly, the AC Distribution/Circuit Breaker Panel, which houses a separate toggle switch circuit breaker for each power supply module in the system. Additional circuit breakers are available for auxiliary equipment mounted in the cabinet.

System prime input power is achieved with an array of modular (hot-swap) power supply chassis. Power is distributed from the power supplies to the SSPA modules via a bus rail assembly.

Each of the power supply modules has its own single phase, 180-264 VAC input. This makes it very convenient to parallel the AC inputs of two modules and connect the array to a three phase AC input source.

The power supply chassis is configured as a n+1 redundant, hot swappable power supply. In the event of a power supply module failure, the amplifier system will not fail. The failed module can be changed without ever taking the HPA out of service. The microwave amplifier architecture is also designed for maximum soft fail redundancy.

Prime system AC Input Power specifications are shown on pages 7-9 for various PowerMAX power levels and configurations.

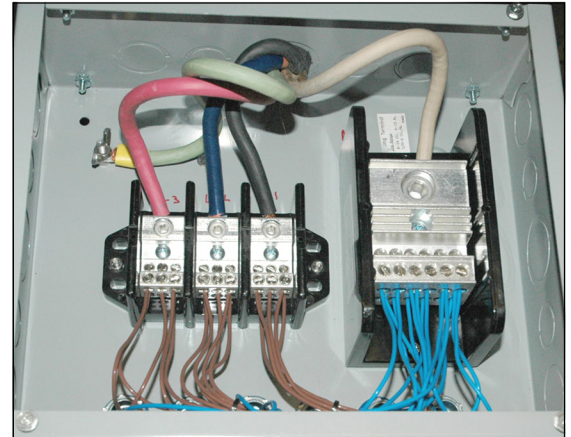

**Terminal Block**



**Circuit Breaker Panel**



**Power Supply Module in Chassis**

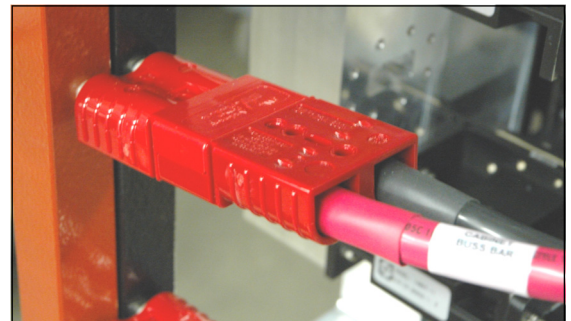

**Quick Connect Plug into Bus Rail**

### Hitless Redundancy

For mission critical systems in which no power outage can be tolerated, an eight module PowerMAX system can be operated with only four modules installed. In this way, the additional four modules can be installed without requiring the system to be powered off.

The only disadvantage of operating the eight module PowerMAX system with four modules is the additional 3 dB loss that the four module (half-system) system experiences by going through the final hybrid combiner as shown at right. Therefore the overall output power is actually 6 dB below what it would be with all eight modules present in the system.

If, however, the module output power is sized such that this reduction in output power can be tolerated, the system shown at right is an effective means of scaling the system from four to eight modules and maintaining true hitless operation. The system never has to be powered down and there are no mechanical switches involved that would create an interruption of service.

With parallel system architectures, the amplifier output power capability and gain will change as the number of active modules vary. The PowerMAX system is designed with an Auto-Gain Control mode so that the overall system gain will remain constant in the event of a single module failure. See the table below.

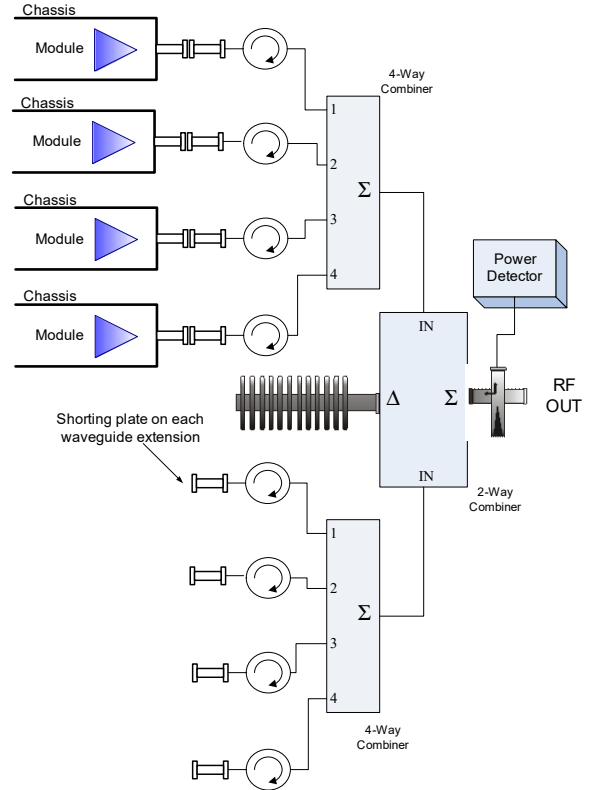

EAR99 Technology Subject to Restrictions Contained on the Back Page.

System Type	# Modules in System	Gain Change Auto Gain Control On	Gain Change Auto Gain Control Off	Maximum Output Power
4-Chassis	3 of 4	0 dB	-2.5 dB	-2.5 dB
4-Chassis	2 of 4	-1.0 dB	-6.0 dB	-6.0 dB
4-Chassis	1 of 4	-7.0 dB	-12.0 dB	-12.0 dB
8-Chassis	7 of 8	0 dB	-1.2 dB	-1.2 dB
8-Chassis	6 of 8	0 dB	-2.5 dB	-2.5 dB
8-Chassis	5 of 8	0 dB	-4.0 dB	-4.0 dB
8-Chassis	4 of 8	-1.0 dB	-6.0 dB	-6.0 dB
8-Chassis	3 of 8	-3.5 dB	-8.5 dB	-8.5 dB
8-Chassis	2 of 8	-7.5 dB	-12.5 dB	-12.5 dB
16-Chassis	15 of 16	0 dB	-0.6 dB	-0.6 dB
16-Chassis	14 of 16	0 dB	-1.2 dB	-1.2 dB
16-Chassis	13 of 16	0 dB	-2.0 dB	-2.0 dB
16-Chassis	12 of 16	0 dB	-2.5 dB	-2.5 dB

### SSPA Chassis Population Options

The PowerMAX system is available in a variety of system module configurations and output power levels. The system is based on Paradise Datacom's 3RU chassis with 100% hot swappable active assemblies. The units can be configured with a wide variety of SSPA frequency bands and power levels, and can be fitted with the following SSPA modules:

- **C Band:**            **100W, 140W, 200W, 250W, 300W, 400W, 500W**
- **X Band:**            **200W**

### Hot-Swap Chassis Features



Removable front panel fan tray

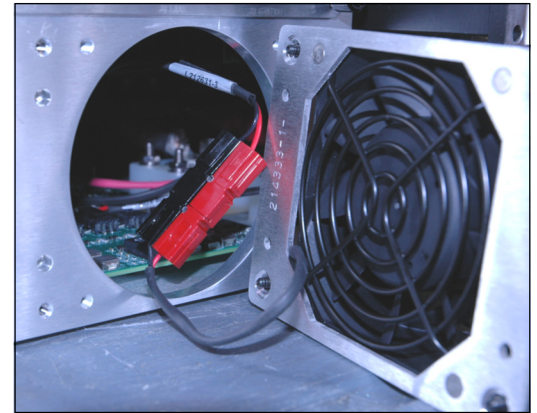

Removable rear panel fan tray

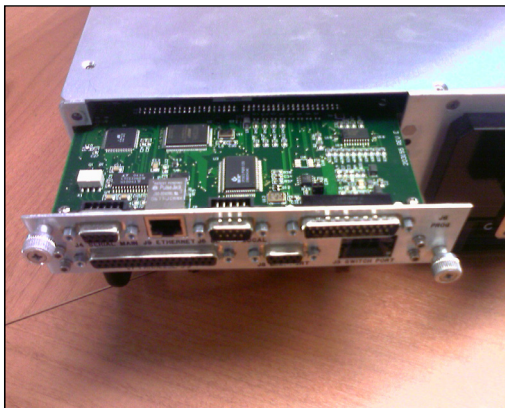

Removable rear panel monitor and control card

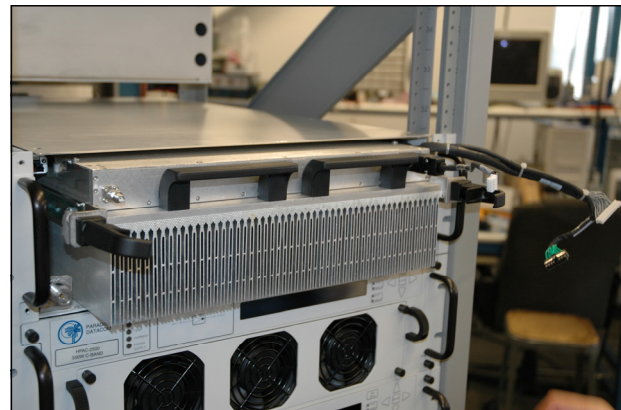

SSPA Module Removal via the front panel

EAR99 Technology Subject to Restrictions Contained on the Back Page.



### 4 SSPA Module System Output & Redundant Power

SSPA Module Power Level	Maximum Output Power 4 modules $P_{sat}$ (typical) dBm (W)	Maximum Output Power 4 modules $P_{1dB}$ (minimum) dBm (W)	Prime AC Input Power @ $P_{1dB}$	Redundant Output Power, 3 modules $P_{sat}$ (typical) dBm (W)	Redundant Output Power, 3 modules $P_{1dB}$ (minimum) dBm (W)
<b>C-Band</b>					
100W	55.2 (331)	54.7 (295)	3,588 W	52.8 (191)	52.3 (170)
140W	56.7 (468)	56.2 (417)	3,974 W	54.3 (269)	53.8 (240)
200W	58.2 (661)	57.5 (562)	5,244 W	55.8 (380)	55.1 (324)
250W	59.2 (832)	58.2 (661)	5,520 W	56.8 (479)	55.8 (380)
300W	60.0 (1000)	59.2 (832)	7,542 W	57.5 (562)	56.8 (479)
400W	61.2 (1318)	60.2 (1047)	9,825 W	58.8 (759)	57.8 (603)
500W	62.2 (1660)	61.2 (1318)	11,592 W	59.8 (955)	58.8 (759)
<b>X-Band</b>					
200W	58.2 (661)	57.5 (562)	5,700 W	55.8 (380)	54.8 (302)

Continuous operation at saturated power can negatively impact the life of the amplifier and will not be covered by warranty. Normal operating output should be limited to  $P_{1dB}$  (1dB backed off from the full rated power,  $P_{sat}$ ).

### **4 Module Systems have 2.5 dB soft-fail redundancy**

For C-Band Frequency selection "B", de-rate output power by 1.0 dB linearly from 6.425 to 6.725 GHz.

For C-Band Frequency selection "C", de-rate output power by 1.0 dB linearly from 5.850 to 5.750 GHz and by 1.0 dB linearly from 6.425 to 6.670 GHz.

### 8 SSPA Module System Output & Redundant Power

SSPA Module Power Level	Maximum Output Power 8 modules $P_{sat}$ (typical) dBm (W)	Maximum Output Power 8 modules $P_{1dB}$ (minimum) dBm (W)	Prime AC Input Power @ $P_{1dB}$	Redundant Output Power, 7 modules $P_{sat}$ (typical) dBm (W)	Redundant Output Power, 7 modules $P_{1dB}$ (minimum) dBm (W)
<b>C-Band</b>					
100W	58.0 (631)	57.5 (562)	7,176 W	56.8 (479)	56.3 (427)
140W	59.5 (891)	59.0 (794)	7,948 W	58.3 (676)	57.8 (603)
200W	61.0 (1259)	60.3 (1072)	10,488 W	59.8 (955)	59.1 (813)
250W	62.0 (1585)	61.0 (1259)	11,040 W	60.8 (1202)	59.8 (955)
300W	62.7 (1862)	62.0 (1585)	14,094 W	61.5 (1413)	60.8 (1202)
400W	64.0 (2512)	63.0 (1995)	19,651 W	62.8 (1905)	61.8 (1514)
500W	65.0 (3162)	64.0 (2512)	23,184 W	63.8 (2399)	62.8 (1905)
<b>X-Band</b>					
200W	61.0 (1260)	59.9 (1000)	11,500 W	59.8 (955)	58.7 (741)

Continuous operation at saturated power can negatively impact the life of the amplifier and will not be covered by warranty. Normal operating output should be limited to  $P_{1dB}$  (1dB backed off from the full rated power,  $P_{sat}$ ).

### 8 Module Systems have 1.2 dB soft-fail redundancy

For C-Band Frequency selection "B", de-rate output power by 1.0 dB linearly from 6.425 to 6.725 GHz.

For C-Band Frequency selection "C", de-rate output power by 1.0 dB linearly from 5.850 to 5.750 GHz and by 1.0 dB linearly from 6.425 to 6.670 GHz.



### 16 SSPA Module System Output & Redundant Power

SSPA Module Power Level	Maximum Output Power 16 modules $P_{sat}$ (typical) dBm (W)	Maximum Output Power 16 modules $P_{1dB}$ (minimum) dBm (W)	Prime AC Input Power @ $P_{1dB}$	Redundant Output Power, 15 modules $P_{sat}$ (typical) dBm (W)	Redundant Output Power, 15 modules $P_{1dB}$ (minimum) dBm (W)
<b>C-Band</b>					
100W	60.7 (1175)	60.2 (1047)	14,352 W	60.1 (1023)	59.6 (912)
140W	62.2 (1660)	61.7 (1479)	13,000 W	61.6 (1445)	61.1 (1288)
200W	63.7 (2344)	63.0 (1995)	15,000 W	63.1 (2042)	62.4 (1738)
250W	64.8 (3020)	63.7 (2344)	22,100 W	64.1 (2570)	63.1 (2042)
300W	65.4 (3467)	64.8 (3020)	24,800 W	64.8 (3020)	64.1 (2570)
400W	66.7 (4677)	65.7 (3715)	45,120 W	66.1 (4074)	65.1 (3236)
500W	67.7 (5888)	66.7 (4677)	58,800 W	67.1 (5129)	66.1 (4074)
<b>X-Band</b>					
200W	63.7 (2344)	62.5 (1780)	23,000 W	63.1 (2040)	61.9 (1550)

Continuous operation at saturated power can negatively impact the life of the amplifier and will not be covered by warranty. Normal operating output should be limited to  $P_{1dB}$  (1dB backed off from the full rated power,  $P_{sat}$ ).

### 16 Module Systems have 0.6 dB soft-fail redundancy

For C-Band Frequency selection "B", de-rate output power by 1.0 dB linearly from 6.425 to 6.725 GHz.

For C-Band Frequency selection "C", de-rate output power by 1.0 dB linearly from 5.850 to 5.750 GHz and by 1.0 dB linearly from 6.425 to 6.670 GHz.

### General Electrical Specifications

PARAMETER	NOTES	LIMITS	UNITS
Gain	Range (Auto-Gain Off) Range (Auto-Gain On)	50-70 45-65	dB dB
Gain Flatness	full band	± 1.0	dB
Gain Slope	per 40 MHz	± 0.3	dB/40 MHz
Gain Variation vs. Temperature	0°C to +50°C	± 1.0	dB
Gain Adjustment	0.1 dB resolution	20	dB
Intermodulation Distortion	@ P <sub>1dB</sub> - 3 dB	-25	dBc
AM/PM Conversion	@ rated P <sub>1dB</sub> @ P <sub>1dB</sub> - 3 dB	3.5 1.0	°/dB °/dB
Spurious Harmonics	@ rated P <sub>1dB</sub> @ rated P <sub>1dB</sub> - 3dB	-65 -50	dBc dBc
Input VSWR Output VSWR		≤ 1.30 : 1 ≤ 2.00 : 1	
Group Delay	Linear Parabolic Ripple	0.01 0.003 1.0	ns/MHz ns/MHz <sup>2</sup> ns p-p
Noise Output	TX Band RX Band (C-Band, without filter) RX Band (X-Band, without filter) RX Band (X-Band, with filter)	-75 -155 -85 -155	dBW/4 KHz dBW/4 KHz dBW/4 KHz dBW/4 KHz
Residual AM Noise	0 - 10 KHz 10 KHz - 500 KHz 500 KHz - 1 MHz	-45 -20 (1.25 + log F) -80	dBc dBc dBc
Residual Phase Noise	Offset frequency from carrier 10 Hz 100 Hz 1 KHz 10 KHz 100 KHz 1 MHz	-90 -100 -110 -120 -125 -130	dBc/Hz dBc/Hz dBc/Hz dBc/Hz dBc/Hz dBc/Hz
RF Leakage	@1m, with SSPA module removed	<0.001	mW/cm <sup>2</sup>

### Environmental Specifications

Operating Temperature	Ambient	0 to +50	°C
Relative Humidity	non-condensing	95	%
Cooling System	Integrated, forced air	137	CFM
Audible Noise <sup>1</sup>	per chassis	71	dBA

<sup>1</sup> Audible noise is measured with the fans set at low. Add 3 dBA to the system audible noise figure (low fan) if using the cabinet rear exhaust impellers.

**System Outline Drawing**

Reference 216503p1-.dxf

The system pictured below is typical for an 4-Module C-Band system.

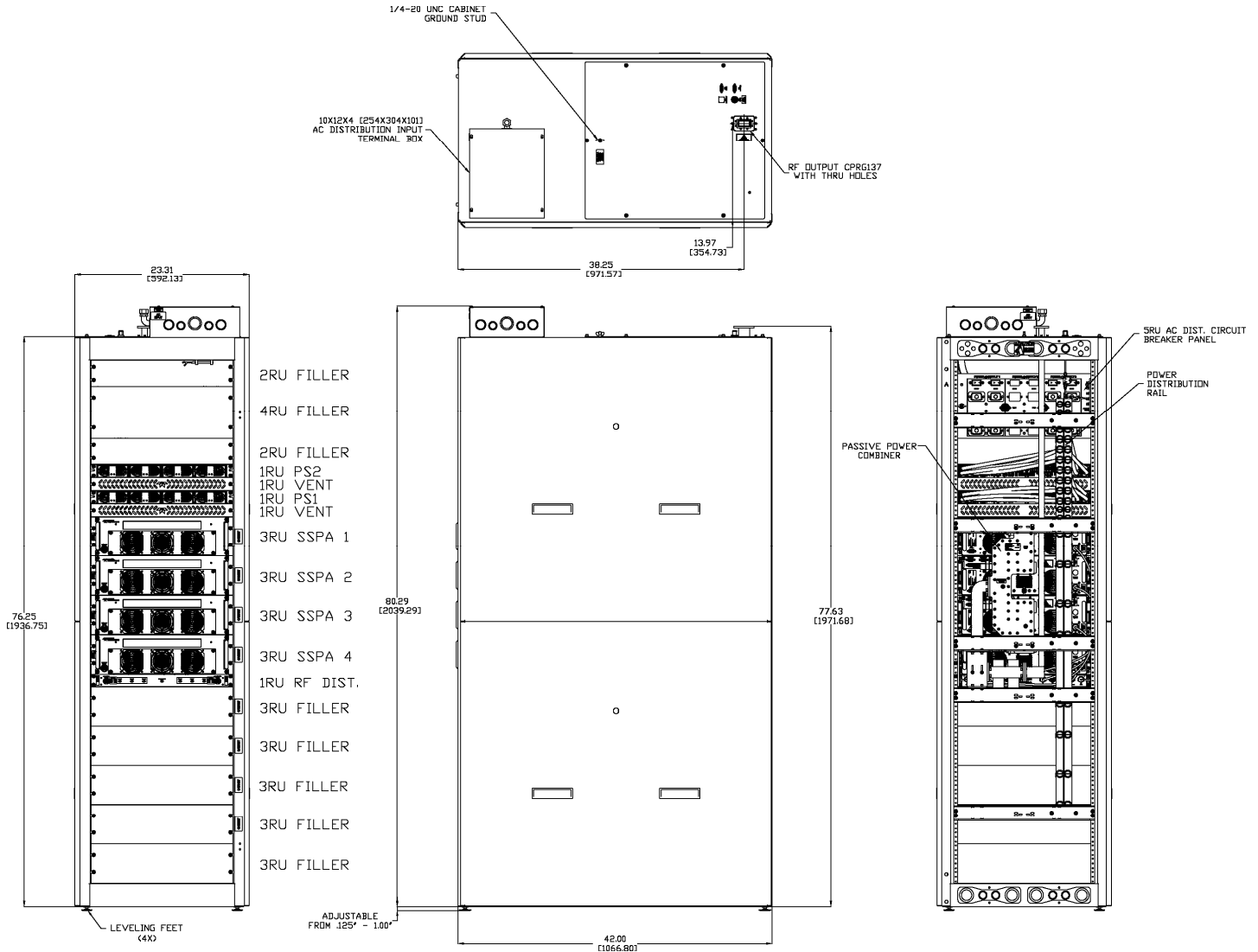

Note that certain power levels require a different power supply configuration. Consult with the factory for details on your system's prime power requirements.

EAR99 Technology Subject to Restrictions Contained on the Back Page.

### Cabinet Exhaust Option

The PowerMAX system is available with an optional cabinet exhaust system, which includes a rear door for the cabinet and an impeller assembly for each grouping of four (4) SSPA chassis in the system.

Power is provided from the AC Distribution Box to the circuit-interruptible power connectors in the interior of the rear door. Separate power cables connect from the outer door couplers to each impeller.

### Outline Drawing, Cabinet Exhaust Option

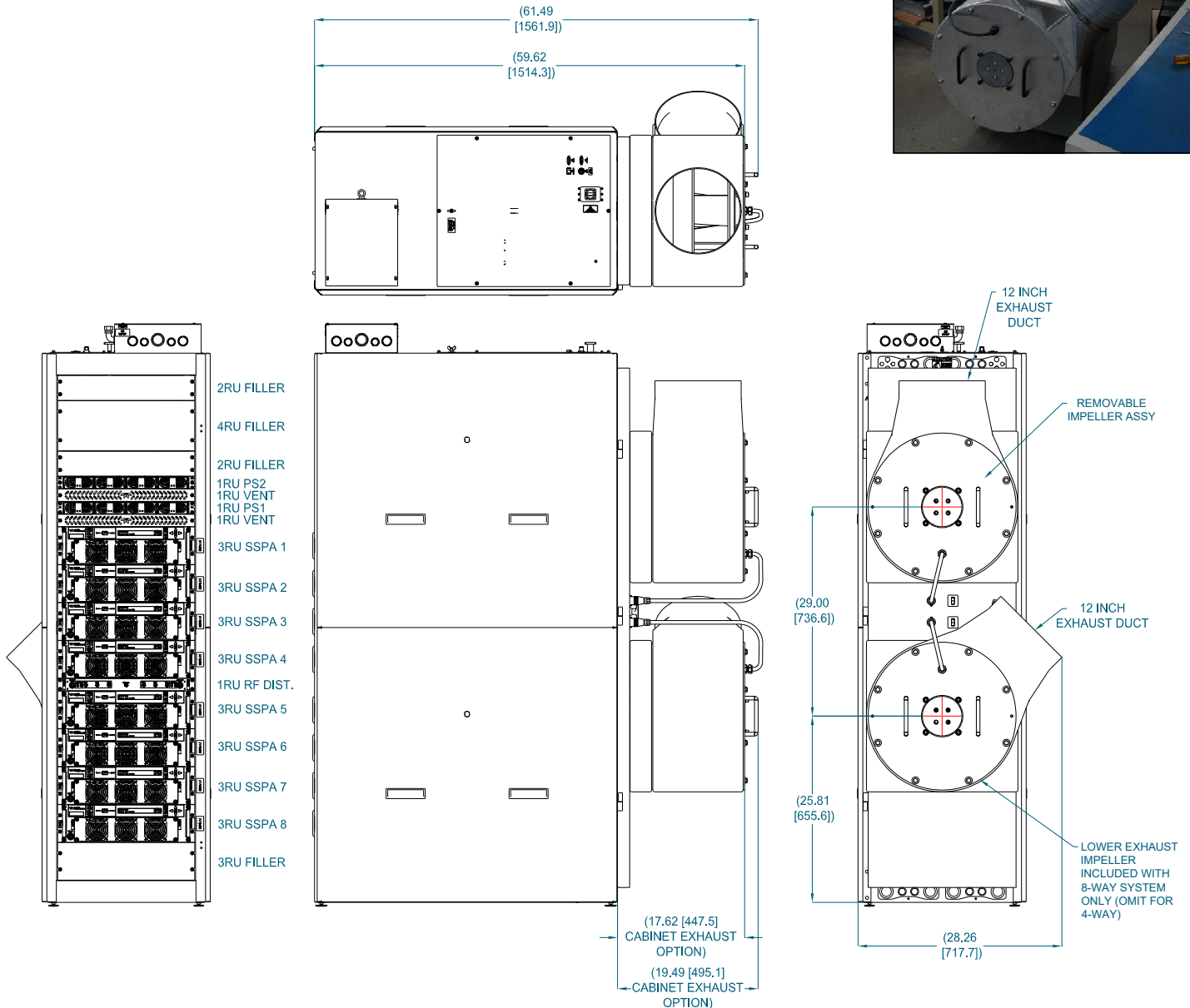

EAR99 Technology Subject to Restrictions Contained on the Back Page.



### Spare Module/Chassis Part Number Configuration

Chassis Power Level (in Watts)		
Band	Output Power	Chassis Config.
C (Low Power)	100, 140, 200, 250, 300	2
C (High Power)	400, 500	(blank)
X (Low Power)	200	2

Chassis Configuration

Output Power

H P A C C 3 0 0 A C X X X X X 2

Band	
C-Band	CC
X-Band	XX

Module Configuration	
M	SSPA Module
C	Single SSPA Chassis

Frequency Sub Band	
C-Band	
5.850 - 6.425 GHz	A
5.850 - 6.725 GHz	B
5.750 - 6.670 GHz	C
X-Band	
7.90 - 8.40 GHz	A

**!** Use this page if ordering a spare SSPA module or single SSPA Chassis for a PowerMAX System.

COMMENTS:

**EXAMPLES:**

250W Low Power C-Band PowerMAX Spare SSPA Module: HPACC250AMXXXXX2  
 250W Low Power C-Band PowerMAX Spare Single Chassis: HPACC250ACXXXXX2

**System Part Number Configuration**

**COMMENTS:**

Chassis Power Level (in Watts)					
Band	System Total Power (# chassis)			Single Chassis	Chassis Config.
	(4) - "F"	(8) - "E"	(16) - "S"		
C (Low Power)	331 W	631 W	1175 W	100	2
	468 W	891 W	1660 W	140	
	661 W	1259 W	2344 W	200	
	832 W	1585 W	3020 W	250	
	1000 W	1862 W	3467 W	300	
C (High Power)	1318 W	2512 W	4677 W	400	(blank)
	1660 W	3162 W	5888 W	500	
X (Low Power)	660 W	1260 W	2344 W	200	2

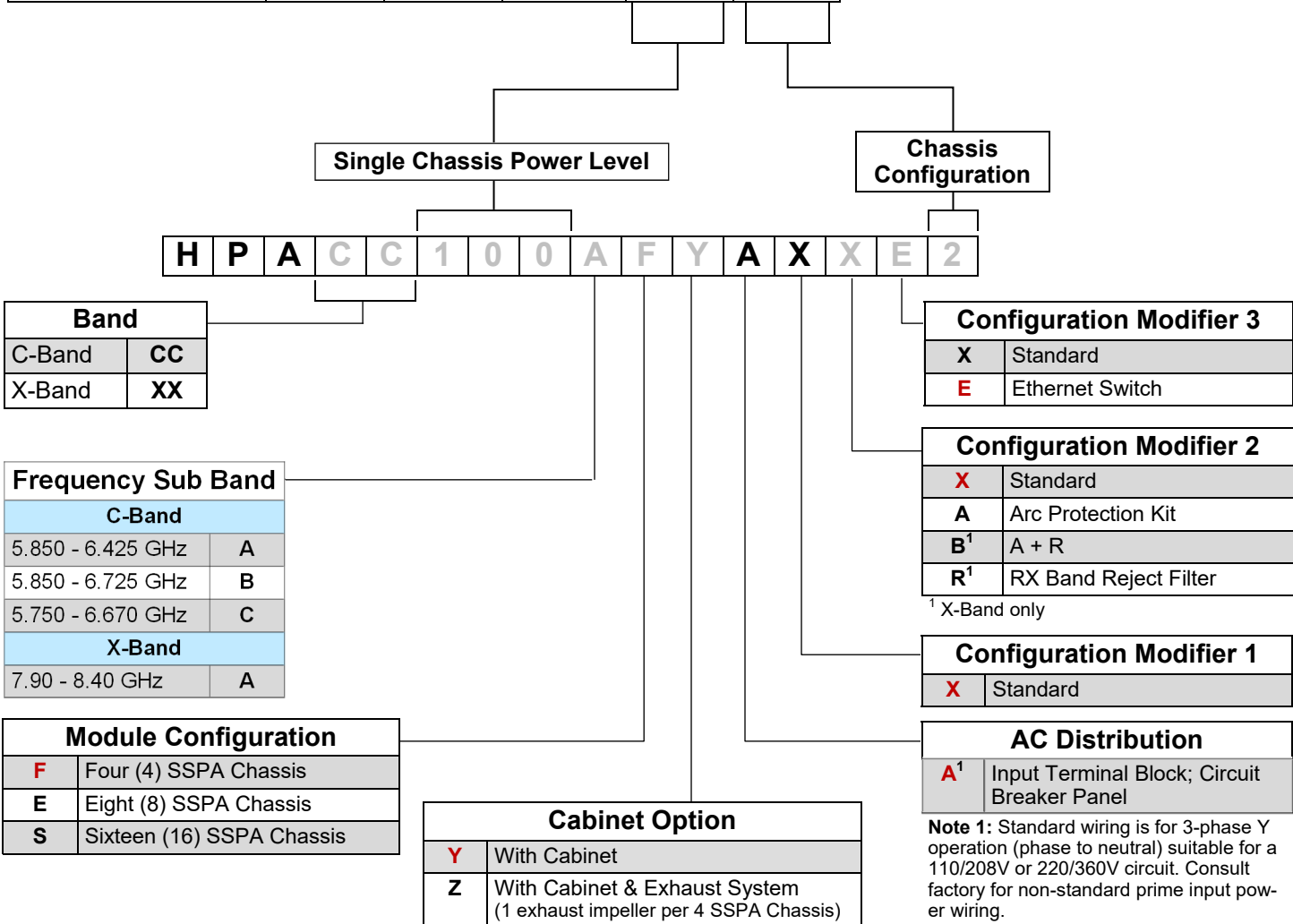

EAR99 Technology Subject to Restrictions Contained on the Back Page.

### Global Sales Offices

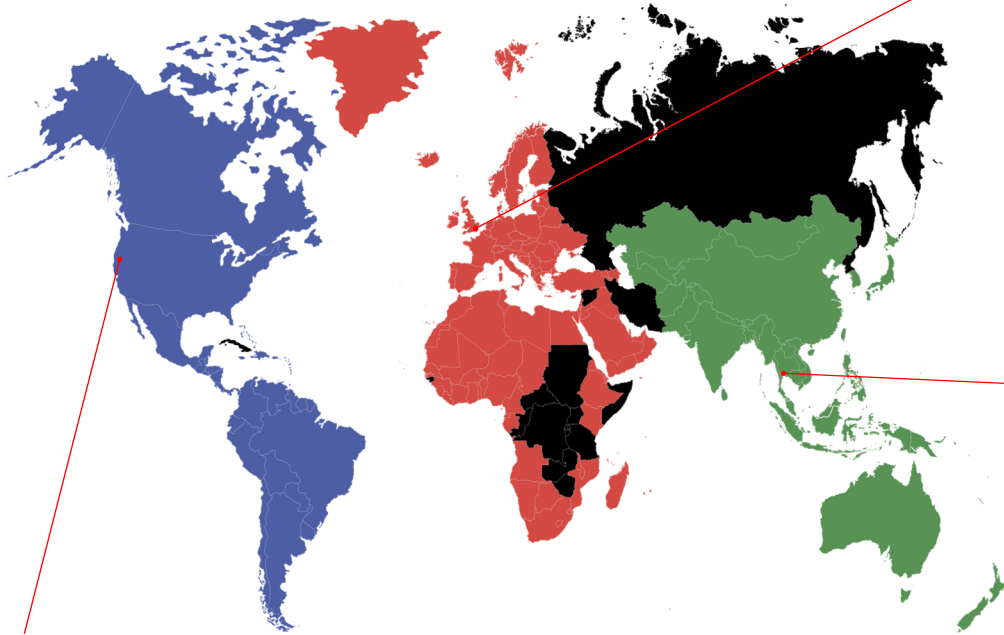

**U.S. HEADQUARTERS (RF)**  
Teledyne Paradise Datacom  
11361 Sunrise Park Drive  
Rancho Cordova, CA 95742  
[sales@paradisedata.com](mailto:sales@paradisedata.com)

**Global Business Development & Sales Director (RF)**  
Timothy Sheerin, (508) 273-5902  
[timothy.sheerin@teledyne.com](mailto:timothy.sheerin@teledyne.com)

**Sales Director, Eastern U.S. & Latin America (RF)**  
John O'Grady, (848) 220-6464  
[john.ogrady@teledyne.com](mailto:john.ogrady@teledyne.com)

**Sales Director, Western U.S. & Canada (RF & Modem)**  
Bruce Grieser, (480) 444-9676  
[bruce.grieser@teledyne.com](mailto:bruce.grieser@teledyne.com)

**U.K. HEADQUARTERS (Modem)**  
**Global Business Development  
& Sales Director (Modem)**  
Paul McConnell  
Teledyne Paradise Datacom  
106 Waterhouse Lane,  
Chelmsford,  
Essex, England, CM1 2QU  
Tel: +44(0)1245 847520  
Mobile: +44(0)7720 707499  
[paul.mcconnell@teledyne.com](mailto:paul.mcconnell@teledyne.com)

**Sales Director,  
Asia Pacific (RF & Modem)**  
Tavechai M.  
Teledyne Paradise Datacom  
333, 20 Fl., C1  
Lao Peng Nguan Tower 1,  
Vibhavadi-Rangsit Rd.,  
Chatuchak, Bangkok 10900  
Thailand  
Tel: +66 2-272-2996  
Mobile: +66 83 5545145  
[tavechai.mektavepong@teledyne.com](mailto:tavechai.mektavepong@teledyne.com)

**Use and Disclosure of Data:** This product is classified as EAR99 and is subject to U.S. Department of Commerce regulations. Export, reexport or diversion contrary to U.S. law is prohibited.

**Proprietary and Confidential:** The information contained in this document is the sole property of Teledyne Paradise Datacom. Any reproduction in part or as a whole without the written permission of Teledyne Paradise Datacom is prohibited.

**Data Security:** Teledyne Paradise Datacom amplifiers and controllers do not inherently provide encryption to transmitted data, and have limited security measures to protect it. If the unit will be accessible over the Internet, exercise appropriate data security protocols. Teledyne Paradise Datacom strongly recommends placing the equipment behind a protective Firewall or setting up a VPN link with dual authentication for remote access.

Specifications are subject to change without notice.